

No. 285
Date: 18.04.2021

New version of Container Lock

As part of the replacing the HASP LOCK by the new DIAMOND LOCK, starting from April 2021 our Container Lock will be based on the DIAMOND LOCK.

The new version will be adjustable to the same clearances as before. Key function remains the same, non-retaining key (key can be removed at both locked & unlocked positions).

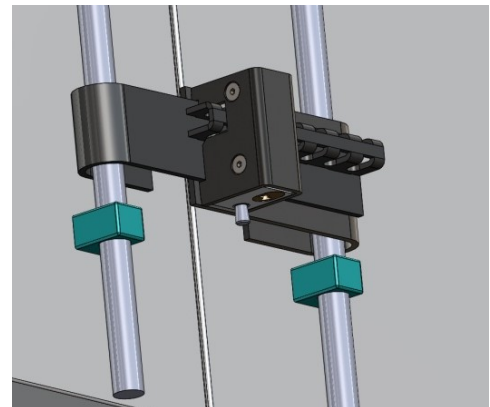
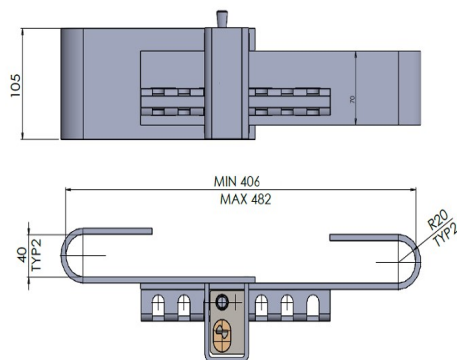

New Features includes:

1. Lock body is made of stainless steel – higher weather resistance.
2. The DIAMOND lock body can be ordered separately from the locking arms and assembled by using two M8 screws and nuts.

* Please ask for new part numbers for your orders.

