



ON LINE UPDATE

MUL-T-LOCK®

NO. 218

DATE: 09.12.08

Modified spool pins – Special groove

As a strong answer to the picking tool offered in the market - especially designed for our cylinder – we have introduced a special spool shaped anti picking body pins.

These pins work in conjunction with special groove we have added in chambers 3,4,5 in the cylinder body (published in the February & October 2008 news letters)

Cylinders equipped with this feature are identified by the letter I stamped next to the production code on the body.

After launch we realized that in some cases the spring can move away from the pin into the chamber groove, causing the pin to get jammed.

In order to keep the spring in place and prevent the pin from jamming we have added a special groove to the pin bottom.

These modified pins are being assembled as standard since November 2008.

You can order these new pins (bag of 100) for servicing "I" stamped cylinders loaded with pre modified pins.

- Nickel Silver, Cat# 51215297
- Stainless Steel, Cat# 51057773

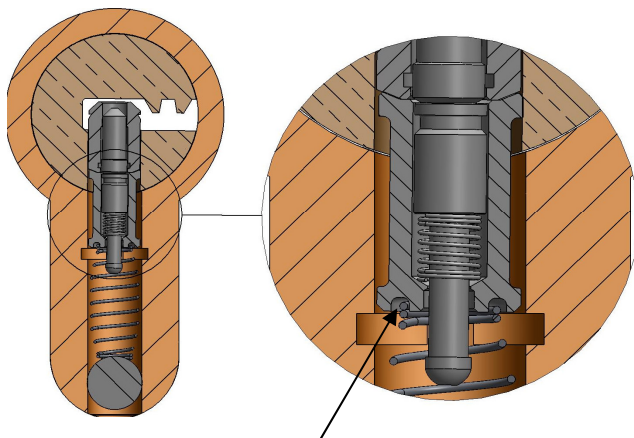

Special groove in the pin

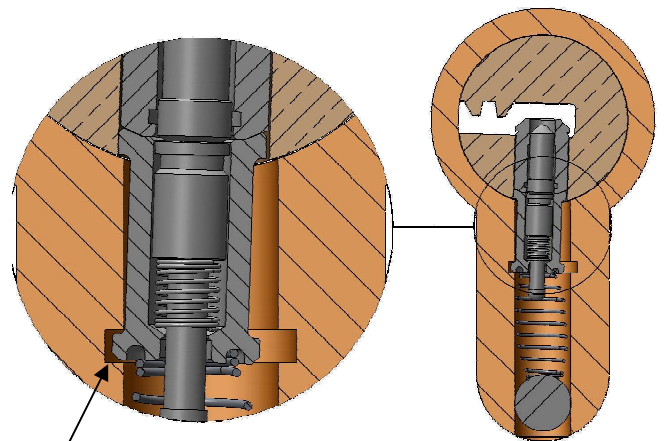

Special groove in the body chamber

Mul-T-Lock Technologies Ltd. Technical Support Unit
Mul-T-Lock Park, Yavne Israel
Tel: 972-8-9424678 Fax: 972-8-9424418
e-mail: rami_a@mul-t-lock.com